

Direct Relief Modular Valve

20 to 50 ℓ /min
0.8 to 21,25,35MPa



Features

- ① This modular relief valve provides maximum pressure control for a hydraulic circuit.
- ② Wide ranging applicability
Maximum Working Pressure: 25, 35MPa {255, 357kgf/cm²}
- Pressure Adjustment Range:
0.8 to 21, 25, 35MPa
{8.2 to 255, 357kgf/cm²}

Specifications

Model No.	Nominal Diameter (Size)	Maximum Working Pressure MPa{kgf/cm ² }	Maximum Flow Rate ℓ /min	Pressure Adjustment Range MPa{kgf/cm ² }	Weight kg	Gasket Surface Dimensions
ORD-G01-W1-20 W3	1/8	25{255}	20	0.8 to 7{ 8.2 to 71.4} 3.5 to 21{35.7 to 214}	1.5	ISO 4401-03-02-0-94
ORD-G01-A1-20 A3				0.8 to 7{ 8.2 to 71.4} 3.5 to 21{35.7 to 214}	1.4	
ORD-G01-B1-20 B3				0.8 to 7{ 8.2 to 71.4} 3.5 to 21{35.7 to 214}	1.4	
ORD-G03-W1-J50 W3	3/8	25{255}	30	0.8 to 7{ 8.2 to 71.4} 3.5 to 25{35.7 to 255}	4.8	ISO 4401-05-04-0-94
ORD-G03-A1-J50 A3				0.8 to 7{ 8.2 to 71.4} 3.5 to 25{35.7 to 255}	4.0	
ORD-G03-B1-J50 B3				0.8 to 7{ 8.2 to 71.4} 3.5 to 25{35.7 to 255}	4.0	
ORH-G04-DW1-10 DW3 DW5	1/2	35{357}	50	0.8 to 7{ 8.2 to 71.4} 3.5 to 25{35.7 to 255} 7 to 35{71.4 to 357}	6.5	ISO 4401-07-06-0-94
ORH-G04-DA1-10 DA3 DA5				0.8 to 7{ 8.2 to 71.4} 3.5 to 25{35.7 to 255} 7 to 35{71.4 to 357}	6.5	
ORH-G04-DB1-10 DB3 DB5				0.8 to 7{ 8.2 to 71.4} 3.5 to 25{35.7 to 255} 7 to 35{71.4 to 357}	6.5	

● Handling

- ① The pressure adjustment range is expressed in terms of cracking pressure.
- ② For use as a safety valve, use a pressure override that is higher than the required circuit pressure.
- ③ Tank port back pressure changes cracking pressure by the corresponding amount.
- ④ Note that a sub plate and installation bolts are not included. See pages D-90 through D-95 if these items are required.
- ⑤ 04 series modular valves do not have an L (DR₂) drain port, so they cannot be used in combination with pressure center type solenoid valves (D).

Understanding Model Numbers

01, 03 size

ORD - G 03 - W 3 - (K) - J50

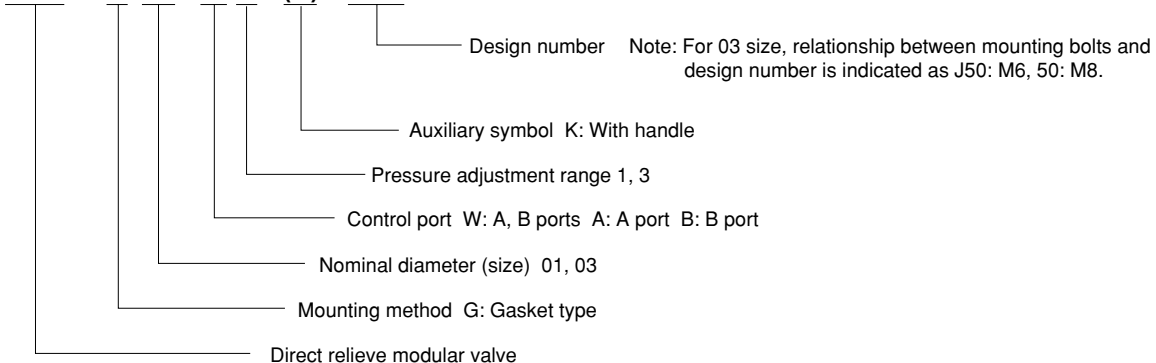

Understanding Model Numbers

04 size

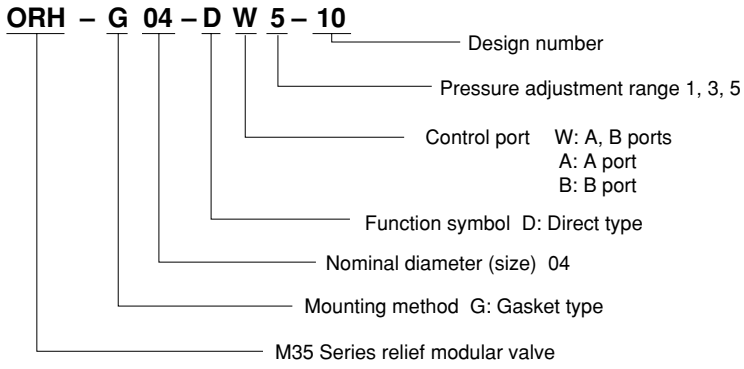

Installation Dimension Drawings

Note)
Pressure is increased by clockwise (rightward) rotation of the adjusting screw (bolt), and decreased by counterclockwise (leftward) rotation.

ORD-G01-W*-20

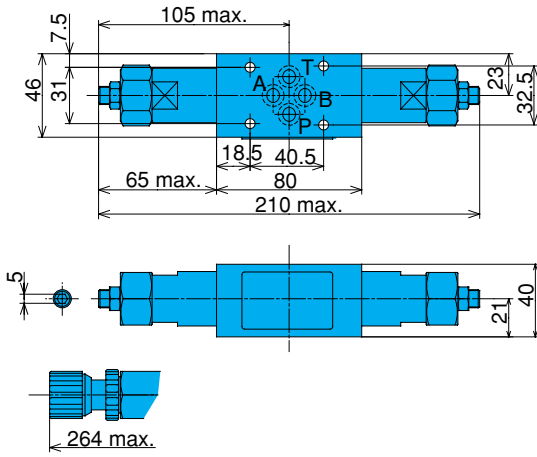

ORD-G01-A*-20

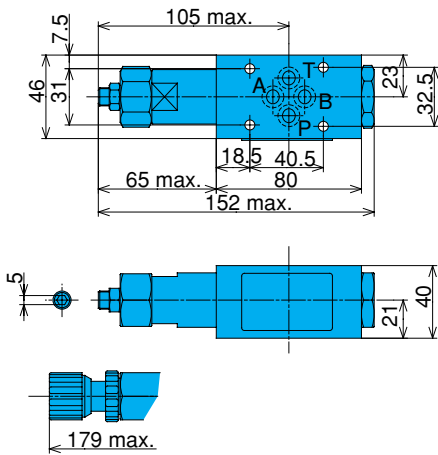

ORD-G01-B*-20

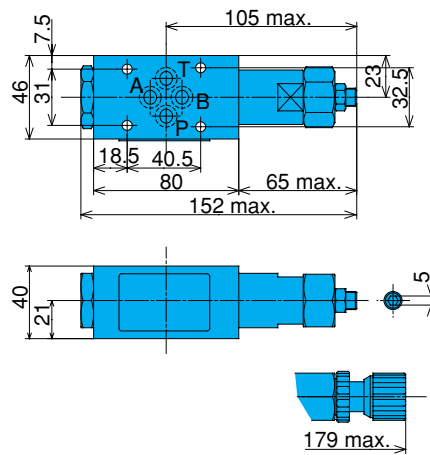

ORD-G03-W*-J50

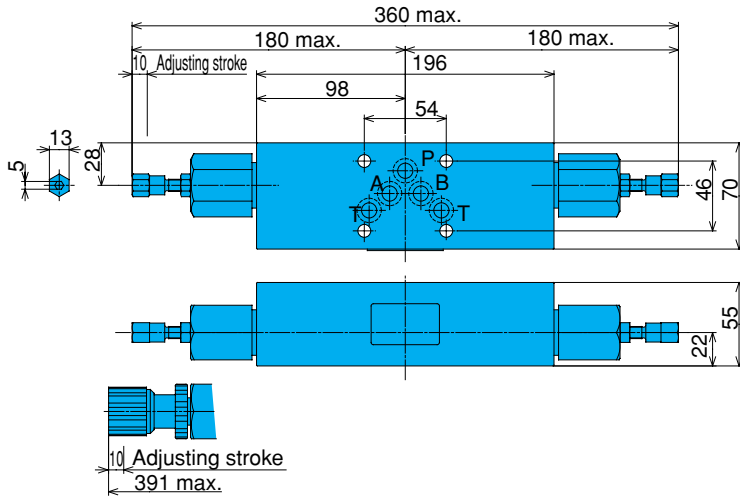

ORD-G03-A*-J50

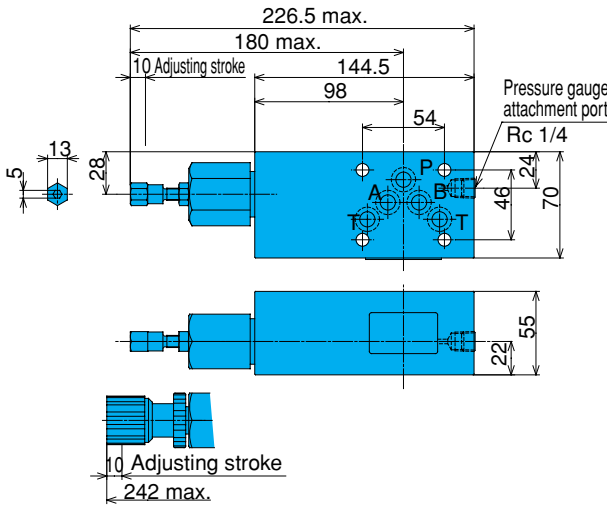

ORD-G03-B*-J50

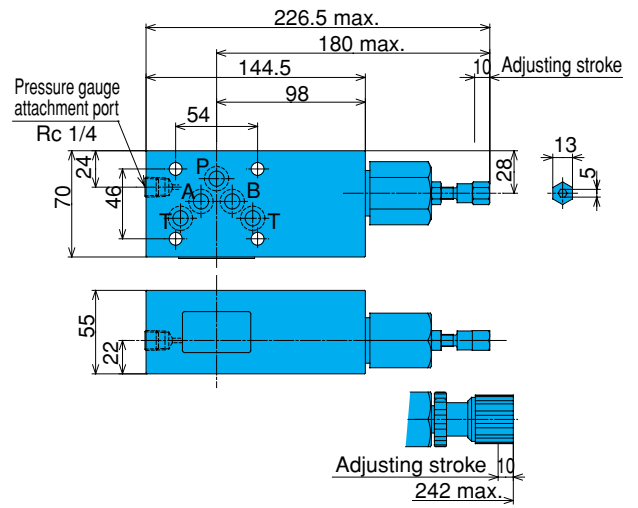

ORH-G04-DW*-10

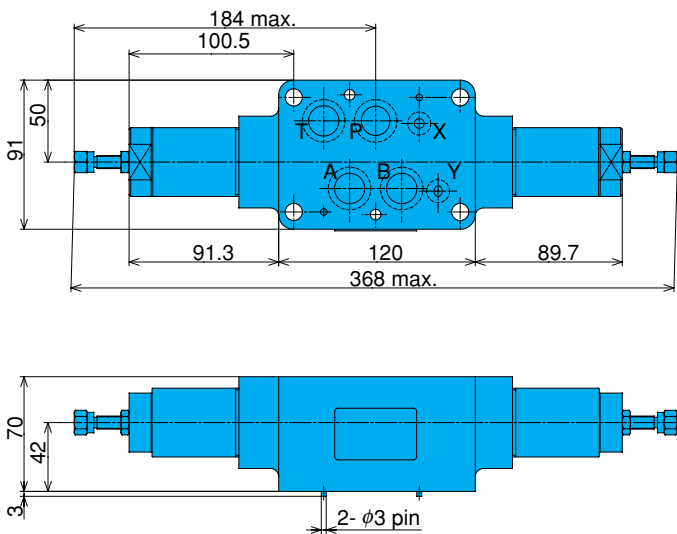

ORH-G04-DA*-10

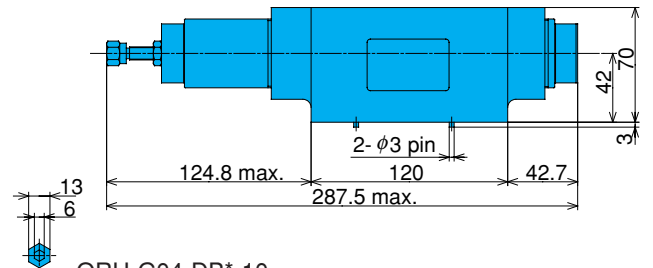

ORH-G04-DB*-10

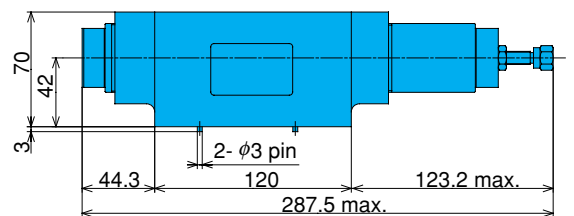

Performance Curves

Differential Hydraulic Fluid Viscosity 32mm²/s

Pressure – Flow Rate Characteristics

ORD-G01-**-20

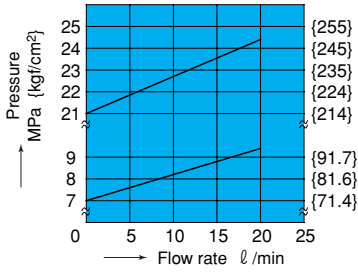

ORD-G03-**-J50

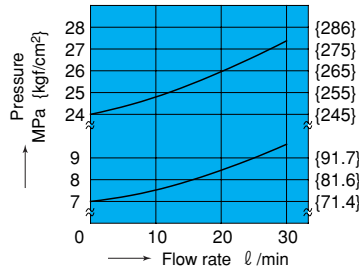

ORH-G04-DW*-10

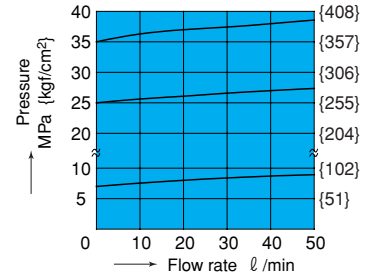

Number of Adjusting Screw Rotations – Pressure Characteristics

ORD-G01-**-20

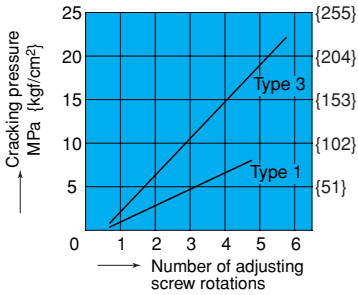

ORD-G03-**-J50

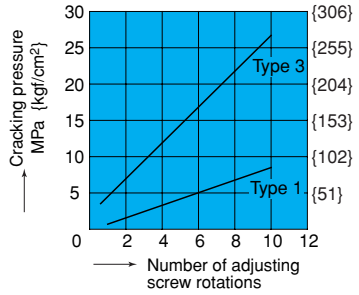

ORH-G04-DW*-10

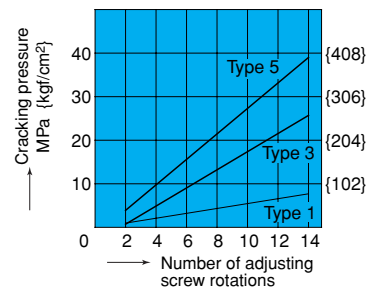

Cross-sectional Drawing

ORD-G01-A*-20

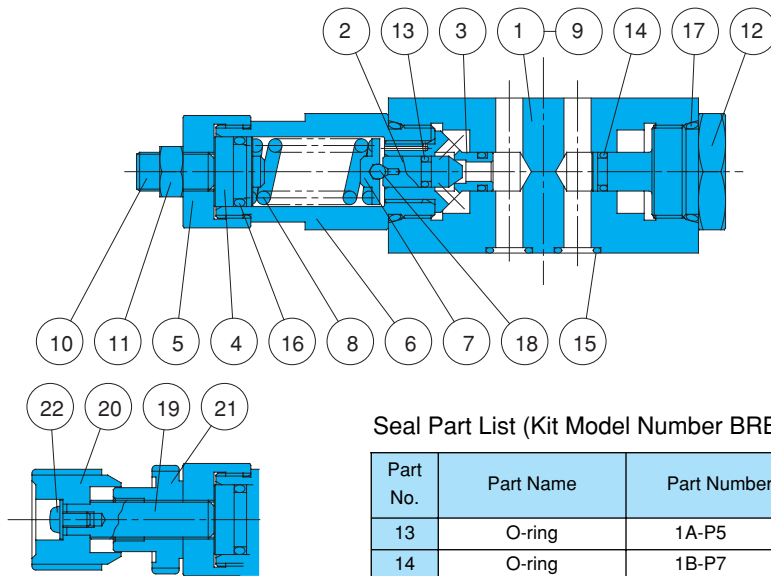

Seal Part List (Kit Model Number BRBS-01RD*)

Part No.	Part Name	Part Number	Q'ty		
			W	A	B
13	O-ring	1A-P5	2	1	1
14	O-ring	1B-P7	2	2	2
15	O-ring	1B-P9	4	4	4
16	O-ring	1B-P14	2	1	1
17	O-ring	1B-P22	2	2	2

Note) 1.O-ring 1A/B-** refers to JIS B2401-1A/B.
2.Specify W, A, or B for the asterisk (*) in the kit model number.

Part No.	Part Name
1	Body
2	Poppet
3	Seat
4	Plunger
5	Bushing
6	Retainer
7	Guide
8	Spring
9	Plate
10	Screw
11	Nut
12	Bushing
13	O-ring
14	O-ring
15	O-ring
16	O-ring
17	O-ring
18	Ball
19	Screw
20	Knob
21	Nut
22	Screw



Modular Valves

ORD-G03-A*-J50

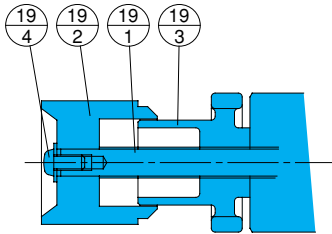
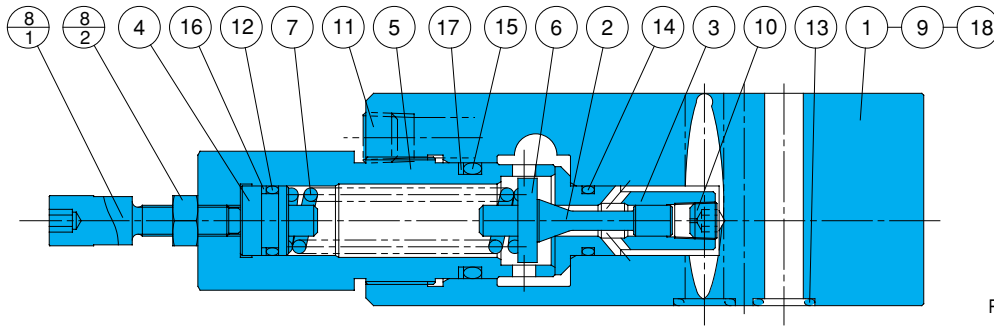

Seal Part List (Kit Model Number BRES-03RD*)

Part No.	Part Name	Part Number	Q'ty		
			A	B	W
12	O-ring	1A-P14	1	1	2
13	O-ring	AS568-014(Hs90)	5	5	5
14	O-ring	1B-P14	1	1	2
15	O-ring	1B-P24	1	1	2
16	Backup ring	T2-P14	1	1	2
17	Backup ring	T2-P24	1	1	2

Note) 1.O-ring 1A/B-** refers to JIS B2401-1A/B.
 2.Backup ring indicates JIS B2407-T2-**.
 3.Specify W, A, or B for the asterisk (*) in the kit model number.

Part No.	Part Name
1	Body
2	Poppet
3	Seat
4	Plunger
5	Retainer
6	Guide
7	Spring
8	Screw kit
8 ₁	Screw
8 ₂	Nut
9	Plate
10	Orifice
11	Plug
12	O-ring
13	O-ring
14	O-ring
15	O-ring
16	Backup ring
17	Backup ring
18	Pin
19	Handle kit
19 ₁	Screw
19 ₂	Knob
19 ₃	Nut
19 ₄	Screw

ORH-G04-DA*-10

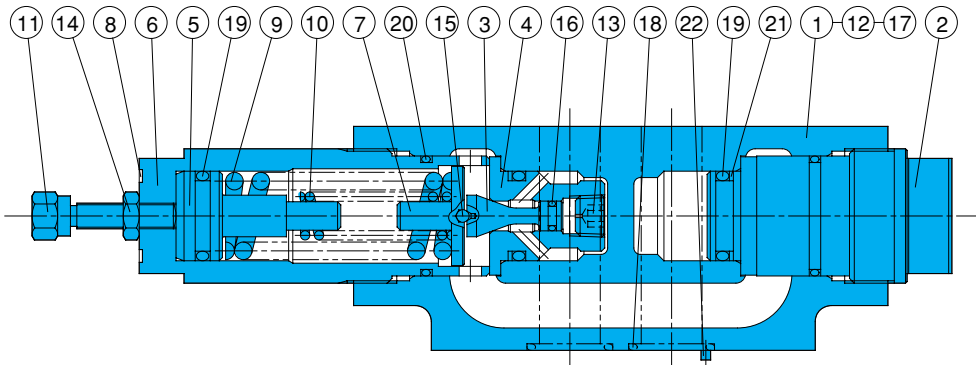

Seal Part List (Kit Model Number BRKS-04RD*)

Part No.	Part Name	Part Number	Q'ty		
			W	A	B
16	O-ring	1A-P6	2	1	1
17	O-ring	AS568-012(Hs90)	2	2	2
18	O-ring	AS568-118(Hs90)	4	4	4
19	O-ring	1B-P22A	4	3	3
20	O-ring	AS568-125(Hs70)	2	2	2
21	Backup ring	T2-P22A	2	2	2

Note) 1.O-ring 1A/B-** refers to JIS B2401-1A/B.
 2.Backup ring indicates JIS B2407-T2-**.
 3.Specify W, A, or B for the asterisk (*) in the kit model number.

Part No.	Part Name
1	Body
2	Plug
3	Poppet
4	Seat
5	Plunger
6	Retainer
7	Guide
8	Plate
9	Spring
10	Spring
11	Screw
12	Plate
13	Choke
14	Nut
15	Ball
16	O-ring
17	O-ring
18	O-ring
19	O-ring
20	O-ring
21	Backup ring
22	Pin